

DATA SHEET N° DS/068	TRASP SYSTEM 900 SERIES SLEEVES HALOGEN FREE	REV: 3
		DATA:02/04/08

DRAWING

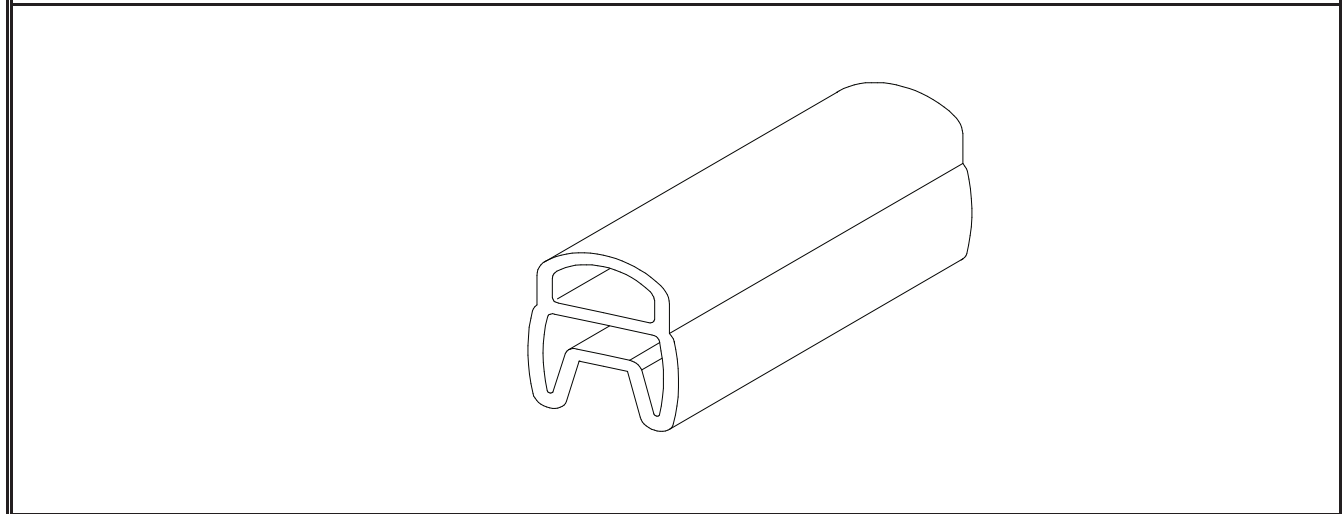

ITEMS OF REFERENCE

901HF - 902HF - 903HF

GENERAL CHARACTERISTICS

SLEEVES SERIES WITH SAME CHARACTERISTICS OF 100 AND 200 SERIES EXCEPT FOR THE MATERIAL, WHICH IS HALOGEN FREE.

CHARACTERISTICS OF THE MATERIAL

TYPE OF MATERIAL	THERMOPLASTIC POLYURETHAN
COLOR	TRASPARENT LIGTH BLUE
TEMPERATURE RANGE	- 40+ 80 °C (-40 ÷ +176 °F)
SELF EXTINGUISHING	CLASS V2 - UL 94
RESISTANCE TO WATER	☺
RESISTANCE TO OILS	☺
RESISTANCE TO DUST	☺
RESISTANCE TO ACIDS	☺
TOXIC MATERIALS, ABSENCE OF	PCB,PCT,PBB,PBDO,VC (MAX. 1 ppm)

CUT LENGTH MM.: 10 - 15 - 18 - 20 - 23 - 30

CUT LENGTH INCH.: 0.39 - 0.59 - 0.91 - 1.18

ITEMS	CABLE EXT. DIAMETER (MM / INCH.)	NO. OF PIECES PER PACK					
		10	15	18	20	23	30
901HF	0.9 ÷ 1.6 / 0.035 ÷ 0.063	1000	1000	1000	500	500	500
902HF	1.4 ÷ 5 / 0.055 ÷ 0.2	1000	1000	/	500	500	500
903HF	5 ÷ 11 / 0.2 ÷ 0.43	500	500	/	200	200	200

NOTES:

PREPARED:	CHECK.,APPROV.	DATE:	SUBJECT MATTER OF REVISION	PAG:
D. Trincherro	CDM	02/04/2008	REVISION	1 of 1